

HCS® – door preparation and installation instructions



HCS® – door preparation and installation instructions



for all HOPPE
door and window handles!

Reliability – Innovation – Design



HCS® is a compact lock and hardware system for the home and office. It is suitable for all timber and glass doors as well as for partition doors.

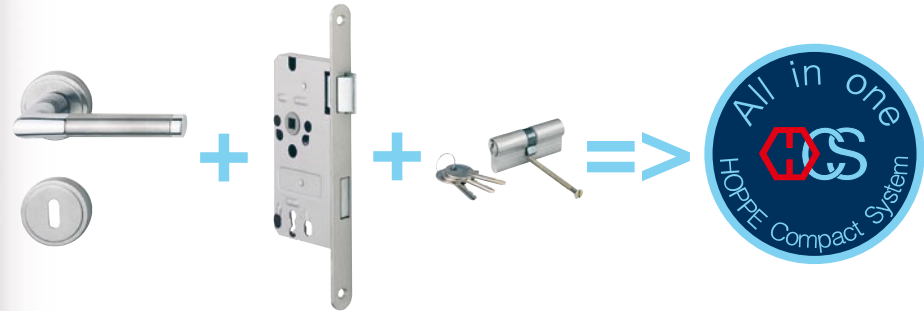

The system consisting of the following components can be installed in less than a minute.



HCS® – tools

Doors not yet prepared for the HCS® can be prepared on site. Please use the tools recommended by HOPPE to ensure lasting, trouble-free operation of the HCS®.

HCS® drill jig

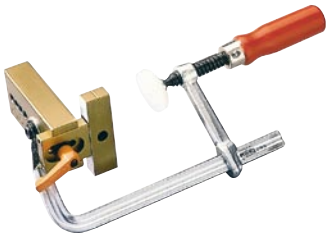

HCS® hole saw Ø 54 mm



HCS® stepped drill bit
Ø 16,2 mm / 22,2 mm



HCS® drill bit Ø 7 mm,
shown on the right

HCS® installation key
accompanying each HCS®



Hole saw Ø 65 mm, for
flush doors of 43 - 53 mm
thickness (on request)



A complete HCS® tool kit is also available
(the hole saw Ø 65 mm is not included)



HCS® – door preparation

HCS® – the preparation of timber doors

- All dimensions are given in mm.
- Backset of 50 mm, 60 mm (standard backset), 70 mm or 80 mm.
- Door thickness of flush doors 25 – 45 (48 – 53 mm), of rebated doors 38 - 43 mm. For other door thicknesses please get in touch with your HOPPE contact partner.
- Handle and latch bolt are at the same height from finished floor level.
- For the preparation of steel frames please contact the manufacturer.

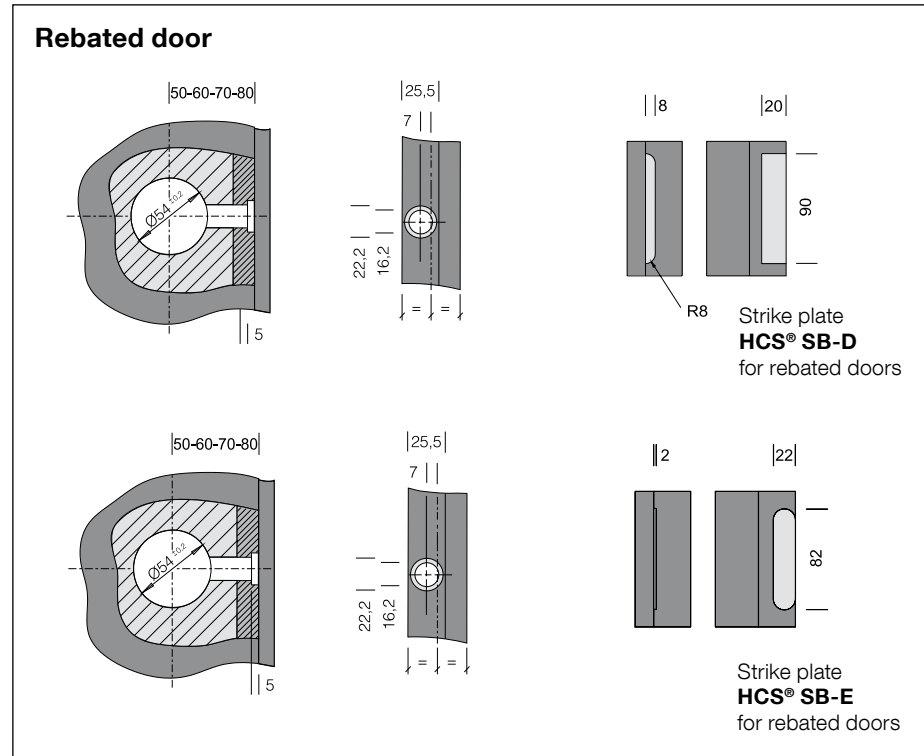
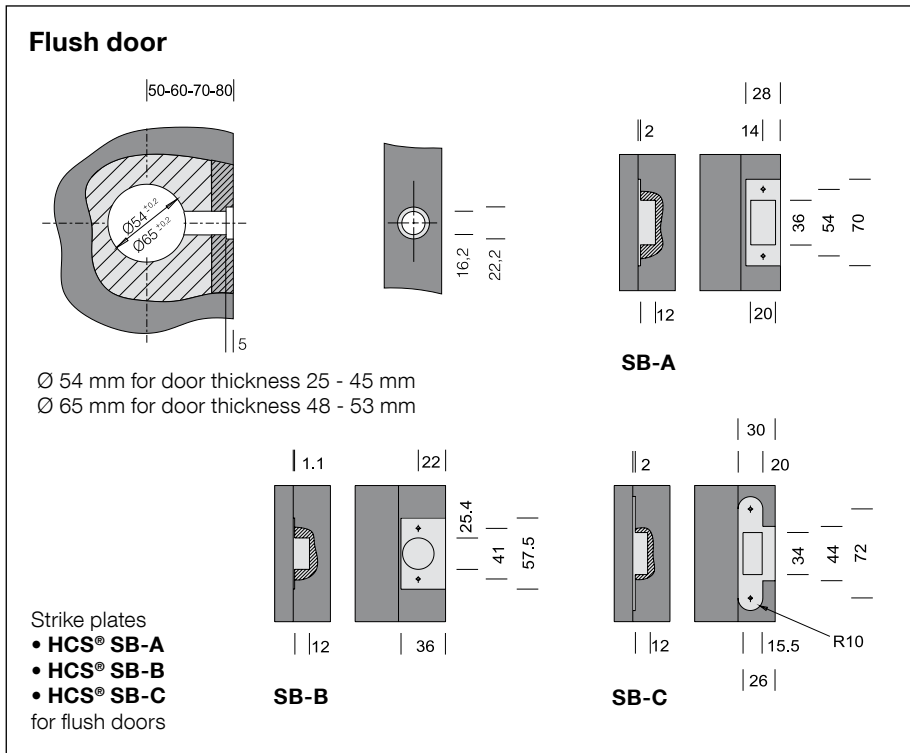

HCS® – the preparation of glass and partition doors

Glass and partition doors should be prepared for the installation of HCS® by the manufacturer as illustrated below.

Preparation of glass and partition doors (active and inactive door leaf) for glass door HCS® and HCS® latch part.



Preparation of glass doors with 20 und 26 mm metal frame to suit HCS® glass door adapter 1) HCS® GD A763 and 2) HCS® GD A764

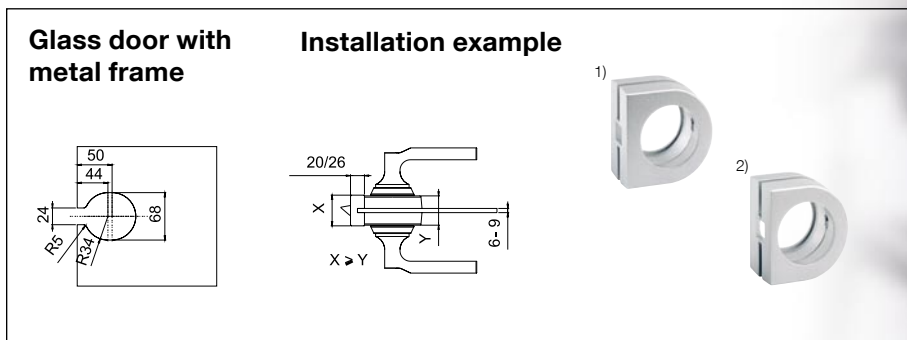

HCS® – door preparation

Only two holes need to be drilled to install HCS®



1 Place HCS® jig at required handle height on door and tighten.



2 **Flush door:** Centre small drill plate on flush edge of door and tighten.
Rebated door: Position small drill plate against rebate and tighten.

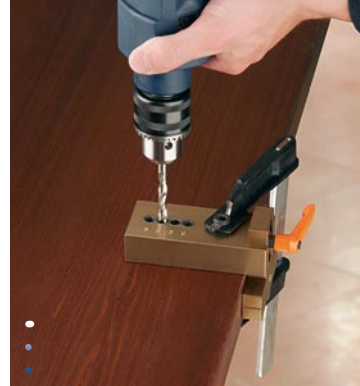

3 Drill Ø 7 mm guiding hole for HCS® drill bit.



4 Drill Ø 7 mm guiding hole for stepped drill bit.

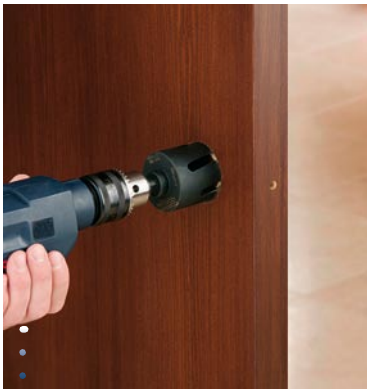

5 Drill 3 mm into door on one side using the Ø 54 mm or 65 mm diameter drill bit.



6 Drill through from opposite side.



7 Drill hole for latch set from flush edge/rebated side of door using HCS® Ø 16,2 mm / 22,2 mm stepped drill bit.



Doors prepared in the workshop for later HCS® fitting on site can be fixed to the frame by a transport latch for protection in transit.

HCS® can be installed in less than a minute



1 Insert the HCS® in the 54 mm hole with the HOPPE logo at the **bottom** and the handles pointing to the **edge of the door**.



2 Turn the handles through 180°. The HOPPE logo is then at the **top** with the handles pointing to the **hinges of the door**.



3 Put the latch tube on the installation key and insert it into the appropriate hole. Position it in the system core and turn it but do **not** tighten completely.

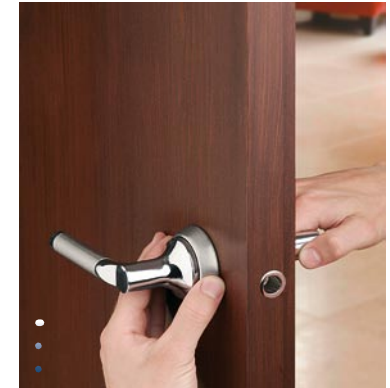

4 Put the **decorative rings** over the handles and turn them tight. Only **now** tighten the latch tube.



5 Put the latch bolt on the installation key and insert it **fully** into the tube with the **strike face of the bolt showing upwards**. Depending on the closing direction of the door, put it to the final position by turning it 90°.



6 That's all!
Depending on the HCS® version chosen, the appropriate clip-in components can now be fitted (see steps 7 - 9).

Note:

Installation of locking HCS®

Before inserting the clip-in components (slotted head piece, turn-button, key cylinder etc.) into the handles, establish their correct position regarding the interior and exterior side of the door. **Once fitted, the clip-in components can't be removed!**

You'll find the instructions for door preparation and installation of the HCS® on every HCS® packaging.



7 The turn button (OL) can be clipped into the handle on the **interior side of the door**.

8 The slotted head piece (SK) or the red/green indicator (RG-SK) can be clipped into the handle on the **exterior side of the door**.

9 Insert the appropriate key cylinder if needed.

HOPPE Holding AG
Via Friedrich Hoppe
CH-7537 Müstair

☎ +41 (0)81 851 66 00
☎ +41 (0)81 851 66 66
✉ info.ch@hoppe.com
🌐 www.hoppe.com

HOPPE AG
Via Friedrich Hoppe
CH-7537 Müstair

☎ +41 (0)81 851 66 00
☎ +41 (0)81 851 66 66
✉ info.ch@hoppe.com
🌐 www.hoppe.com

HOPPE China Ltd.
16/F Mirage Tower
15 Thomson Rd, Wan Chai
Hong Kong

☎ +852 2866 0866
☎ +852 2866 0366
✉ info.asia@hoppe.com
🌐 www.hoppe.com

HOPPE AG
Representative Office Finland
Hyrylänkatu 8 C 15
FIN-04300 Tuusula

☎ +358 (0)9 25 84 34 24
☎ +358 (0)9 25 84 00 26
✉ info.skandi@hoppe.com
🌐 www.hoppe.com

HOPPE AG
Am Plausdorfer Tor 13
D-35260 Stadtallendorf

☎ +49 (0)6428 932-0
☎ +49 (0)6428 932-220
✉ info.de@hoppe.com
🌐 www.hoppe.com

HOPPE AG
Jaufenstrasse 16
I-39010 St. Martin i.P. (BZ)

☎ +39 0473 640-111
☎ +39 0473 641-444
✉ info.it@hoppe.com
🌐 www.hoppe.com

HOPPE China Ltd.
Representative Office Beijing
25 D, Tower A, Star City
10 Jiuxianqiao Road
CN-Beijing 100 016

☎ +86 0(10) 6431 67 64
☎ +86 0(10) 6431 66 14
✉ info.asia@hoppe.com
🌐 www.hoppe.com

HOPPE AG
Representative Office Sweden
Storgatan 15

S-434 30 Kungsbacka
☎ +46 (0)300 177 23
☎ +46 (0)300 177 24
✉ info.skandi@hoppe.com
🌐 www.hoppe.com